

6KW Diesel Combi Air & Water Heater

4kw diesel+2kw electric

Technical Instructions, Installation, Operation and Maintenance Instructions

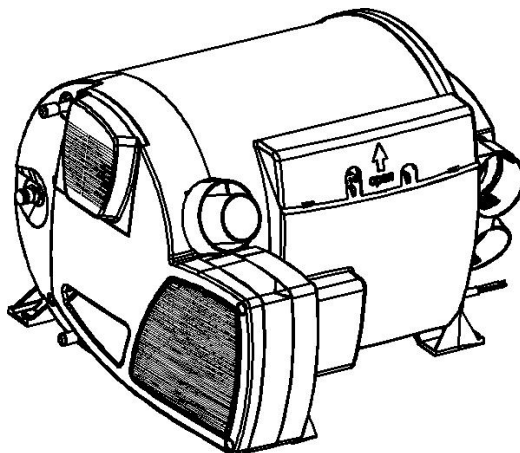

Type of product category

Order number

Diesel Electric Heating DC12V/220VAC

4W2005 12C11

Preface

Thank you for Using JP Heater

This manual describes the technical instructions, installation, operation and maintenance of JP Diesel Combi heater. To ensure the correct use of the heater, please read this manual carefully before installation and use. Please keep this manual for reference.

Note:

- The contents of this manual are subject to change without notice, but it can be guaranteed that this manual is consistent with the purchased products.
- We try our best to express clearly the problems that users shall know in this manual. If you have any questions or find anything wrong, please contact us directly.
- When the user unpacks the box for the first time, please check the main machine and accessories according to the packing list. If problems are found, please contact the seller immediately.
- If there is a problem in use, please contact our marketing department or the customer service stations authorized by us. We will serve you wholeheartedly.

Please carefully keep the after-sales service warranty bill and give feedback as required. This is the only valid proof of after-sales service.

Notes

The product must be installed and used according to the requirements of this manual to ensure long-term use!

1. Application

FJH-4/1C-E type diesel combi air and water heater (hereinafter referred to as the Heater) is a special heater integrating hot water and warm air for motor homes. The Heater cannot be used for passenger cars or dangerous goods transport vehicles.

2. Main technical parameters

Rated voltage	DC12V	
Operating voltage range	DC10.5V~16V	
Short-term maximum power consumption	8-10A	
Average power consumption	1.8-4A	
diesel type	Diesel	
diesel thermal power	2000	4000
diesel consumption ml/h	240	510
Quiescent current	1mA	
Warm air supply m ³ /h	287max	
Tank capacity	10L	
Maximum pressure of water pump	2.8bar	
Maximum system pressure	4.5bar	
Electrical mode voltage	~220V	
Electrical mode thermal power	900W	1800W
Electrical mode power consumption	3.9A	7.8A
Working (environmental) temperature	-25°C~+80°C	
Operating altitude	≤5000m	
Main machine weight	15.6Kg(without water)	
External dimension (mm)	510×450×300	
Protection grade	IP21	

Table 1

3. Functions

The Heater integrates hot water and warm air, providing hot water for living while heating passengers. It can be used during driving. The Heater can also realize heating with electrical mode.

In the hot water and warm air operation mode, the Heater can be used to for room heating and water heating. If only hot water is required, please select the hot water operation mode.

When the ambient temperature is lower than 3°C, please empty the water in the water tank to prevent freezing of the water tank.

There are three energy options:

-Diesel mode

The heater automatically adjusts the power.

-Electrical mode

Select the 900W or 1800W heating mode manually according to the power supply capacity of the motor home camp.

-Mixed mode

When the power demand is low (for example, at the stage of maintaining room temperature), electrical mode is preferred. The diesel mode will not be started until the electrical mode can not satisfy the demands, and the diesel mode function shall be turned off first in the power adjustment stage.

In the hot water operation mode, the diesel mode or the electrical mode is used to heat the water tank. The temperature of the water tank can be set to 40°C or 60°C.

--Diesel mode

The heater works with the lowest power. Stop heating as soon as the set temperature is reached.

--Electrical mode

Select the 900W or 1800W heating mode manually according to the power supply capacity of the motor home camp.

4. Safety instructions

Safe working environment

--The device can only be operated with appropriate control panels and accessories.

--The danger of toxic waste gas. If the vehicle is parked in a closed room, the exhaust gas from the heater may be toxic in the closed space (e.g. garage, maintenance workshop). Therefore, the fuel supply of the water heater and the timing switch shall be turned off. And the heater shall be turned off through the control panel.

--If an exhaust hood is installed near or under an open window, the device must be equipped with an automatic closing device to prevent the opening of the window.

--Heat-sensitive objects (e.g. spray cans) or flammable materials/liquids cannot be stored in the same compartment as the equipment because the area may be affected by high temperatures in some cases.

--Flammable items shall be kept away from the warm air outlet to prevent the block of the warm air outlet.

--For the opening of circulating air intake, the space around the installation room and the installation unit must not be restricted by obstacles, so that the equipment will not overheat.

--At all times, keep the exhaust pipe, exhaust cowl (inlet and outlet) and combustion air inlet free from pollution (slush, ice, leaves, etc.).

--The danger comes from the heated wall surface and exhaust gas around the smoke exhaust cowl. Do not touch the area of the wall around the smoke exhaust cowl, and do not lean anything against the smoke exhaust cowl on the wall or the vehicle.

Obligations of Operator/Owner

--The owner is responsible for filling the container of the heater with water and for its maintenance.

--The owner has the responsibility to operate the equipment correctly.

--Liquid fuel systems must comply with national technical and administrative regulations. National legislation and regulations must be abode by.

--Check the water pipeline regularly. If the water pipe breaks, please replace it.

--If the water heater is not in use, drain the water from the water heater to prevent frost. We will not maintain or compensate for the damage caused by frost.

Safe operation

--Make sure the car is well ventilated. When the heater is started, there may be some smoke or smell due to dust or dirt, especially when the equipment has not been used for a long time.

--This equipment may be used by children over the age of 8 under the guidance of their adults.

--The integrity and close cooperation of the exhaust double pipes must be checked regularly, especially at the end of a long journey. It is also necessary to check the installation of the device and smoke exhaust cowl.

--When cleaning the vehicle, do not spray water directly into the smoke exhaust cowl.

5. Installation of the Heater

Typical installation drawing of the Heater is shown in figure 1.

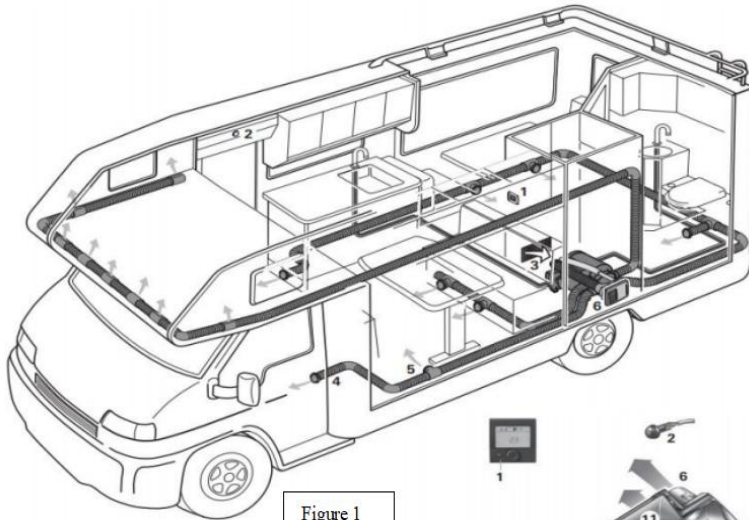

Figure 1

- 1-LCD Control Switch
- 2-External Temperature Sensor
- 3-Circulating Air Inlet (150cm² at least)
- 4-Warm Air Pipe
- 5-Warm Air Outlet
- 6-Smoke exhaust cowl

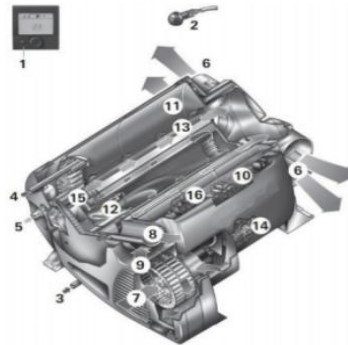

Figure 2

★Installation and maintenance must be carried out by professionals authorized by the Company!

The Company will not be liable for any of the following acts:

- Modification to heaters and accessories
- Modification to exhaust pipes and accessories
- Do not follow the operation and installation instructions
- Do not use special accessories of the Company

- 1- LCD Control Switch
- 2- External Temperature Sensor
- 3- Cold Water Inlet
- 4- Hot Water Outlet
- 5- Diesel Interface
- 6- Warm Air Outlet
- 7- Circulating Air Inlet
- 8- Exhaust Port
- 9-Combustion Air Inlet
- 10-Main Control Panel
- 11-Water Tank
- 12-Burner
- 13-Heat Exchanger
- 14-Electric Control Panel
- 15-Electric warm air pipe
- 16-Overheating Switch

Figure 3 Schematic diagram of heater installation

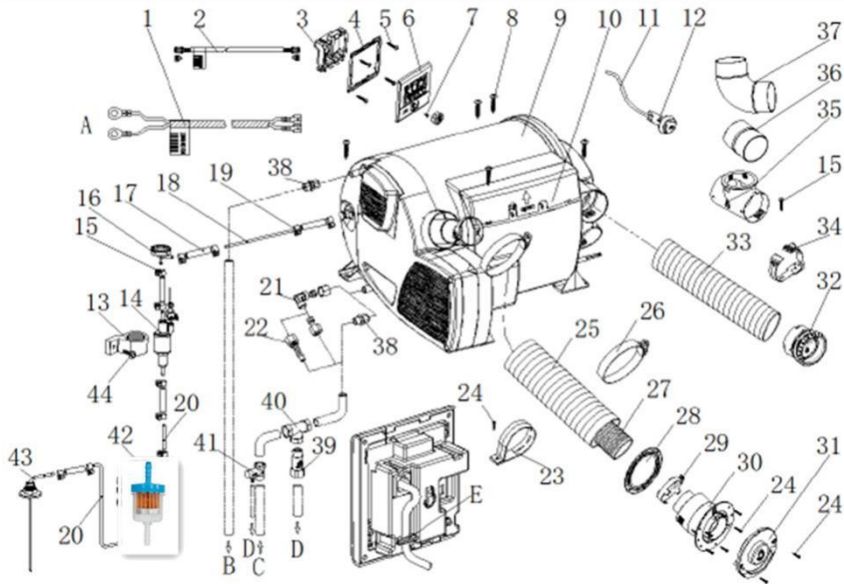

Figure 3

- 1_12V Power Cord 2_LCD Switch Lead 3_LCD Switch Rear Cover 4_LCD Switch Bracket 5_Self-tapping Nail M3*10 6_LCD Switch 7_Cross Countersunk Head and Flat Tail Self-Tapping Nail M3*6 8_Self-Tapping Nail St5*25 9_Main Machine 10_Controller Cover Plate 11_External Temperature Sensor Lead 12_External Temperature Sensor 13_Oil Pump Fixing Sleeve 14_Oil Pump 15_oil-conveying pipe Clamp (φ9-11) 16_Buffer 17_Tubing Connector 18-Nylon Tubing (Transparent,from main machine to oil pump) 19_Tubing Clamp (φ8-10) 20_Nylon oil-conveying pipe (Blue, from oil tank to oil pump) 21_Φ 10 Steel (Water) Pipe Bent Transition Joints 22_Soft (Water) Pipe Transition Joint 23_Intake Pipe Fixing Clip 24_Self-tapping Screw St 3.5× 25_Intake Pipe 26_German Clamp 27_Exhaust Pipe 28_Sealing Rubber Gasket 29_(Exhaust Pipe) Clamp 30_Inlet and Outlet Body 31_Inlet and Outlet Cover 32_Air Outlet 33_Warm Air Pipe 34_ducting Buckle 35_φ60 Tee-junction 36_φ60 Straight 37_φ60 Bent 38_G1/2-φ10 Fixing Sleeve Connector 39 Anti-Freezing Valve 40_G1/2 Tee-junction 41_Pressure Reducing Valve 42_Diesel Filter 43_Suction Pipe Combination 44_Self-Tapping Self-Drilling Nail St5.5*30 A_Connecting to 12V Battery B_Connecting to Water Equipment C_Connecting to Water Tank of the System D_Draining out of the Vehicle E_Hook for Sticking the LCD Switch Lead

The installation position of heater shall be selected as load-bearing floor, double-layer floor or sub-floor. If there is no suitable floor, a bearing surface made of plywood can be used first.

★ The heater must be firmly fixed to the installation surface with screws to prevent the danger caused by damage to the diesel pipe during the driving process of the car.

According to the actual installation situation, only three screws can be installed. After fixing by two die-cast aluminum fixing screws, a plastic right angle can be used for further fixing.

To ensure uniform heat distribution of the heater, the installation position of the heater shall be centered as far as possible so as to make the warm air pipes as long as possible.

The heater surface cannot be covered with any additional covering.

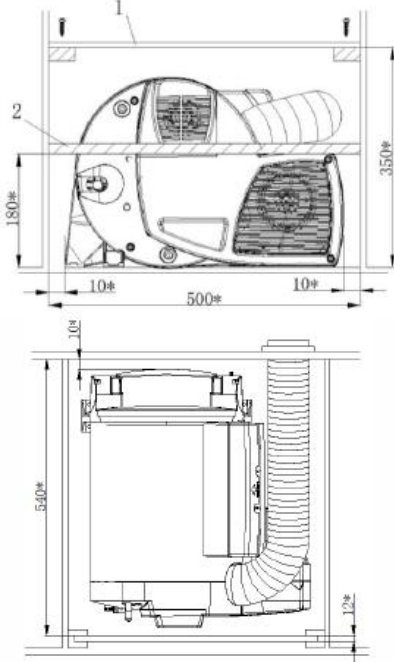

Figure 4

Size with * refers to the minimum size. And enough space shall be left for connecting accessories such as diesel and water pipes.

To prevent the danger caused by accidental loosening of the heater, the upper cover plate of the heater compartment is fixed with screws (figure 4-1). Next to the installation position, it is necessary to install a strong partition bar in front of the heater, perpendicular to the direction of travel. 180mm above the floor height, spacers can be attached (minimum 30*50mm).

Heat-sensitive and flammable objects shall be kept away from the Heater.

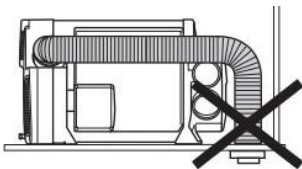

Figure 5

★ **Smoke exhaust cowl** (inlet and outlet) must be placed on the **side wall or top plate**. In the exhaust hood layout area, there shall be no ventilation window within the range of 300mm and no oil filler or oil tank respirator within the range of 500mm. The smoke exhaust cowl is installed close to under the window that can be opened. A window switch shall be installed to ensure that the heater is automatically turned off when the window is opened.

Installation of intake and exhaust pipes

The exhaust pipe passes through the intake pipe.

As shown in figure 6, the length of the intake and exhaust pipes is 60cm at the shortest and 100cm at the longest. The exhaust cowl can only be 20cm below the exhaust port.

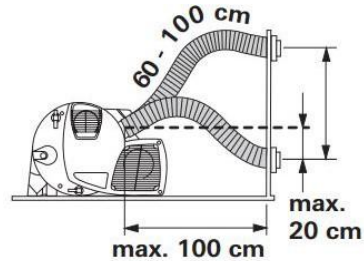

Figure 6

After the intake and exhaust pipes pass through the via hole, they must be cut short. The exhaust pipes are slightly shorter than the intake pipes so as to avoid excessive expansion of or tension on the exhaust pipe.

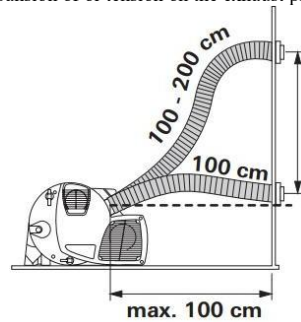

Figure 7

The length of the intake and exhaust pipes is 100cm to 200cm, as shown in figure 7. The pipes must be arranged in the ascending direction.

Installation of smoke exhaust cowl (inlet and outlet)

Flat mounting surface shall be selected so that combustion air can enter from all sides. Drill a $\Phi 83$ hole. Seal it with a seal (figure 8-8) with the plane facing the smoke exhaust cowl. Install the fixing clamp before installing the exhaust pipe (figure 8-3). Pay attention to the upward mark of the smoke exhaust cowl during installation.

The 20mm-long part at the end of the smoke exhaust pipe shall be compressed and not straightened. Insert the smoke exhaust pipe into the smoke exhaust cowl interface (figure 8-10) as deep as possible. Set the fixing clamp up as far as possible and tighten it.

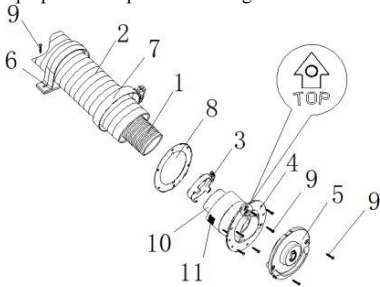

Figure 8

Cover the teeth of the smoke exhaust cowl (figure 8-11) with the air inlet pipe (figure 8-2). Put on the fixing clamp (Figure 8-7) and tighten it. Fix the smoke exhaust cowl with 6 screws (figure 8-9). Fix the smoke exhaust cowl with 2 screws.

The intake and exhaust pipes can be fixed to the side wall with fixing clamps (figure 8-6).

The intake and exhaust pipes are installed on the Heater

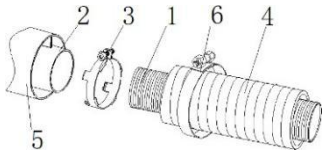

Figure 9

The 20mm-long part at the end of the smoke exhaust pipe (figure 9-1) shall be compressed and not straightened.

Insert the exhaust pipe into the exhaust outlet (figure 9-2) as deep as possible. Set the fixing clip up as far as possible and tighten it.

Insert the air inlet pipe (figure 9-5) into the air inlet pipe (figure 9-3). Install the fixing clamp (figure 9-6) and tighten it.

Warm air intake

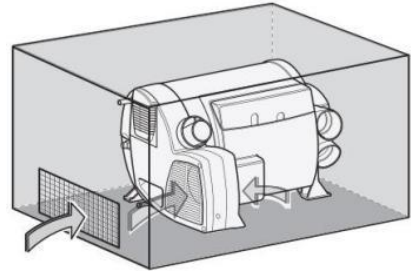

Figure 10

The warm air intake is sucked in by the heater. There must be an opening with a total area of not less than 150cm^2 between the room and the Heater.

Ensure that the warm air intake is not polluted by engine or heater exhaust, and use structural isolation measures when necessary.

Warm air distribution

Most of the warm air is introduced into the floor area of the living room through ducting.

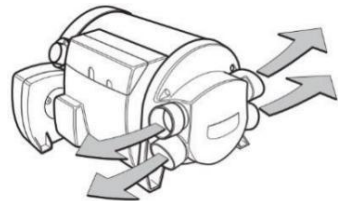

Figure 11

Four air outlets on the heater are connected with $\Phi 60$ ducting. Only pressure pipes that meet the quality requirements of the Company can be used. Other pipes that do not meet our quality standards (especially wind resistance, pipe diameter and corrugation number) shall not be used.

If the warm air duct must withstand considerable elbowing immediately after the hot air outlet of the heater in a limited space, we recommend using a 90° elbow (figure 3-37). This kind of elbow can connect the hot air pipe with a diameter of 60mm.

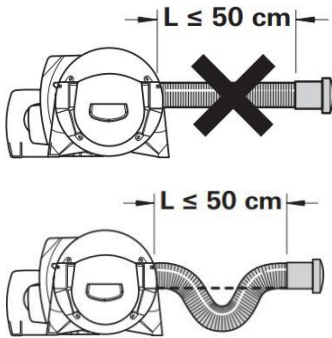

Figure 12

When the length of the pipe is less than 2 meters, the air outlet shall not be installed at a place higher than the connector of the warm air pipe. When the length of the pipe is less than 50 cm, there shall be a siphon between the connector and the outlet for the pipe. These measures prevent undesirable heating of the vehicle due to convection (fairing effect) during summer operation.

★ The warm air pipe must be firmly inserted into the connector.

★ To obtain the best warm air distribution, the Company requires the use of all 4 warm air outlets of the Heater.

★ **The cross section of the warm air pipe shall not be reduced due to duct connection or the like.** In other words, the opening number of warm air duct outlets (figure 3_32) shall not be less than four, and it shall be ensured that more than four warm air outlets are open.

diesel system connection

diesel is extracted from the vehicle diesel tank or supplied from a 10L special diesel tank, and is delivered and adjusted by a special oil pump (provided by the manufacturer). It is not allowed to extract diesel from the return system of the vehicle engine or downstream of the internal transfer pump of the vehicle. Please use the diesel hoses and pipelines within the scope of delivery only for installation.

The diesel oil shall conform to the national standard GB19147-2013 *Standards for Vehicle Diesel Oil*.

During winter, the diesel used shall meet the requirements of low temperature. Bio-diesels are not allowed.

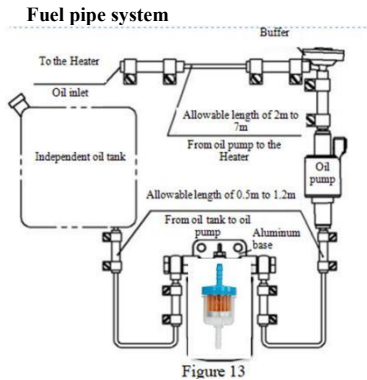

Figure 13

Installation of oil-conveying pipes

Oil-conveying pipes must be the kit's accessories, namely nylon hoses with good light resistance and thermal stability. Allowable diesel pipe length: the maximum length of the diesel pipe on the oil inlet side is 2m, and that of the diesel pipe on the pressure side is 6m. As shown in figure 13

Safety regulations for diesel pipes

Be sure to use a hose cutter or a sharp knife to cut the diesel hose and pipes to a certain length. The cut area cannot be compressed and must be free of burrs. The diesel pipes must be firmly connected to prevent damage and/or noise caused by vibration (the recommended distance between connection points is about 50 cm). diesel pipes must be protected from mechanical damage. The laying of diesel pipes will not adversely affect the stability of vehicle rotation, engine operation, etc. Protect diesel-carrying components from high temperatures that may affect operation (use suitable fiberglass-lined aluminum thermal protection hose). Do not set or fix the diesel pipe near the Heater or the exhaust line of the vehicle engine. If the lines cross, keep a sufficient distance from the hot parts—if necessary, provide thermal radiation protection plates. The installation position of the oil pipe shall be able to prevent flying stones from hitting, and shall be far away from the heating parts of the vehicle, and protective devices shall be installed when necessary.

Installation of oil pump

The oil pump shall be fixed with an oil pump fixing sleeve (rubber). The oil outlet of the oil pump shall be inclined upward, and its installation angle shall be between 15° and 35° (as shown in figure 14). When conditions permit, the oil pipe from the oil pump to the heater main machine shall gradually rise. To prevent the oil pump from being heated (the maximum working temperature is 40°C), it shall not be installed near the exhaust pipe. The height difference between the diesel level and the oil pump and the height difference between the oil pump and the oil inlet of the main machine will generate pressure (or suction) in the oil circuit, so these dimensions shall meet the requirements of figure 14.

Connection of the Heater and oil pump

The direction of the oil pipe from the oil pump to the main machine shall be as upward as possible. Mark holes for connecting cables through diesel lines and oil pumps at appropriate locations on the vehicle floor. Before drilling, be sure to check the hidden cables, diesel pipes, frame

sections, etc.

Then, seal the edge of the opening on the vehicle floor with the underbody protector. To prevent the cable of oil pipe and oil pump from being cut, please add the lead-in bushing or section edge protection material.

Oil pipes shall be tied and fixed at suitable places with the binding spacing not more than 50cm.

The connection between the oil pipe and the oil pump, the main machine and the oil tank (oil suction nozzle) shall use the oil pipe connector provided for the Heater. The connector shall be clamped tightly with the oil pipe clamp. Bubbles at the joint shall be prevented (figure 15).

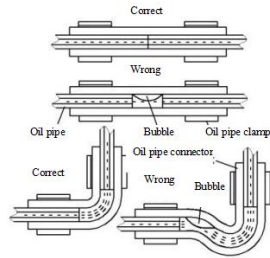

Figure 15

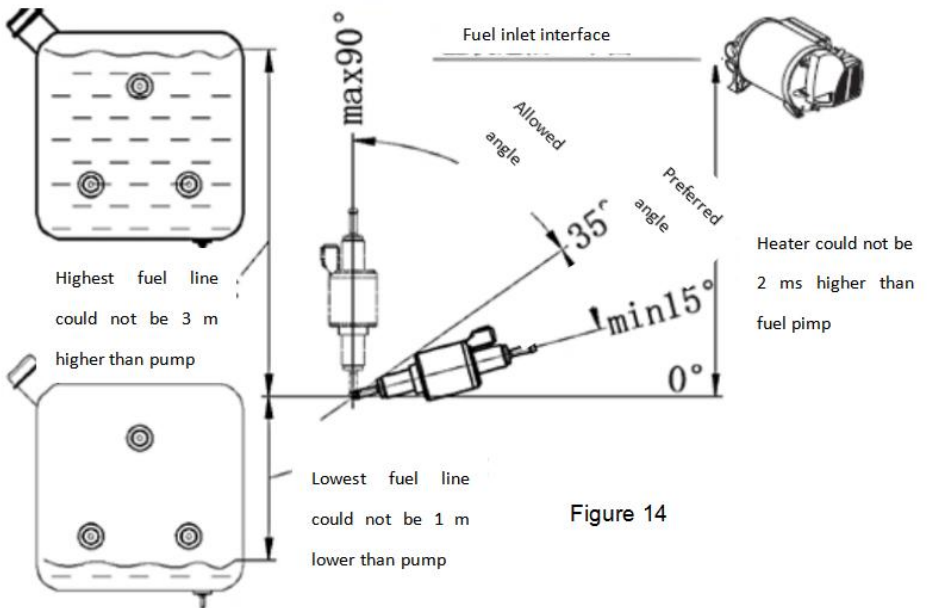

Figure 14

Figure 14

Installation of fuel filter

Install the diesel filter in front of the oil inlet of the oil pump.

During installation, it shall be noted that the fuel filter must be vertically upward (to ensure that impurities deposit downward).

The replacement cycle of the fuel filter is two years. The oil pipe joint and clamp must be replaced at the same time.

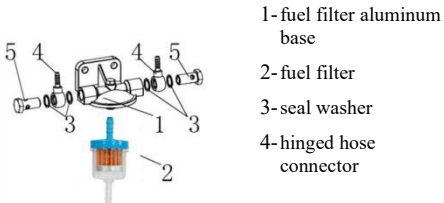

- 1- fuel filter aluminum base
- 2- fuel filter
- 3- seal washer
- 4- hinged hose connector

5- Hinged bolts

Figure 16

Installation of the oil suction nozzle (figure 17)

First, cover the O-type ring with oil suction nozzle, and then make it pass through the $\Phi 8$ hole at the bottom (processed as required) from the inside of the oil tank. Wear a washer on the outside of the oil tank and tighten it with a nut. The tightening torque is $6\text{Nm}+1\text{Nm}$. The O-type ring must be sandwiched between the inner side wall of the oil tank and the oil suction nozzle to ensure a good seal between the oil suction nozzle and the oil tank. (oil suction nozzle and other accessories are carried in the oil tank)

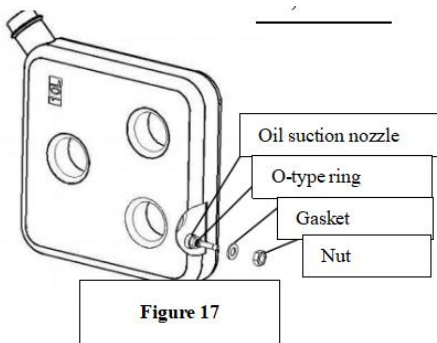

Figure 17

Installation of oil suction pipe (figure 21)

Use when drawing diesel suction from the vehicle's diesel tank. During installation, ensure that the size of the installation opening on the oil tank (or tank cover) is $\phi 25\pm 0.2$. The edges shall be neat and surroundings shall be smooth to ensure a good seal with the oil suction pipe seat. The distance between the lower opening of the oil suction pipe and the bottom of the oil tank shall be 30 to 40mm, **which can not only ensure the full absorption of diesel, but also prevent the impurities deposited at the bottom of the oil tank from being sucked in.**

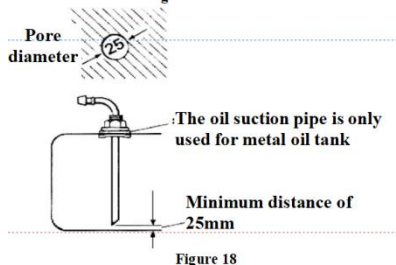

Figure 18

Water pipe connection

The water tank can be supplied with water by a pressure pump or an immersion pump with a pressure of 2.8bar.

If the water tank is connected to a centralized water supply (rural or urban connection), or if a high-pressure pump is used, a pressure reducer must be used, which will prevent pressure above 2.8bar.

★ Before the pressure relief valve is triggered, the temperature rise of water and its expansion may lead to a pressure up to 4.5 bar (which may also occur together with the immersion pump). The water pipes connected to the water tank and the safety/drain valve must be water pipes with safe drinking water, pressure resistance (up to 4.5bar) and hot water resistance up to 80°C.

Anti-freezing valve (figure 3-39, anti-freezing automatic drain valve), a mechanical safety/drain valve. When there is danger of frost, it will automatically drain the water from the water tank through the drain outlet.

Pressure reducing valve must be installed (figure3-41, 0.5MPa). If there is excessive pressure in the system, the pressure will be automatically released intermittently through the pressure reducing valve.

Installation of external temperature sensor

The sensor is installed in the vehicle to measure room temperature. The installation position of the sensor is determined by the motor home manufacturer according to the specific conditions of the vehicle. When selecting the installation location, please note that the external temperature sensor shall not be exposed to direct thermal radiation.

To obtain the best room temperature control, an external temperature sensor is installed above the entrance door.

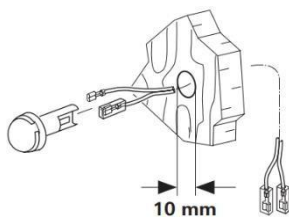

Figure 19

Please ensure that the external temperature sensor is always installed on the vertical wall. There must be free flowing air around it.

Drill a hole with a diameter of 10 mm. The single-wire terminal passes through the opening from the rear. Connect the end of the cable to the sensor with an insulated connection plug (polarity needs not be observed). Push in the external temperature sensor and connect both ends of the cable with the two insulated connection plugs to the heater electronics (if necessary, extend the cable to a maximum length of 10 meters. 2 x 0.5 mm² cable).

The provided external temperature sensor must always be connected, otherwise the Heater will switch to failure.

Installation of LCD switch

The Heater must be operated using a dedicated LCD switch. Please refer to the relevant instructions for details.

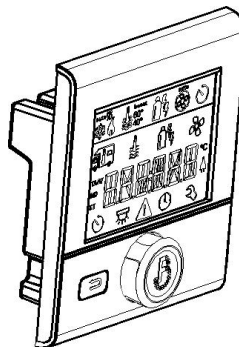

Figure 20

Electrical appliance connection

Scratches shall be avoided during wires laying. If there are sharp edges, such as metal panel threading, please use lead bushing or edge protection fittings.

Connector cables shall not adhere to or contact metal surfaces, exhaust pipes or hot air pipes.

The electrical connection socket is located below the controller cover. The controller cover can be removed by pressing and simultaneously pushing in the direction of the arrow.

When removing or installing the controller cover, make sure that the connecting cable is not pulled out or squeezed.

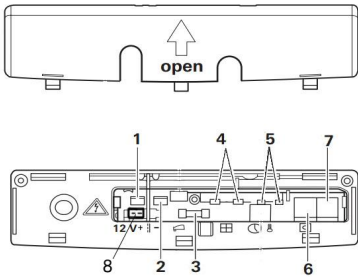

- | | |
|--------------------------------|---------------------|
| 1-DC12V Positive | 2-DC12V Negative |
| 3- Fuse | 4-Window Switch |
| 5- External Temperature Sensor | 6,7- Control Switch |
| 8-Oil pump | |

Figure 21

When the window switch is not installed, the short wiring cannot be removed.

All cables connected to the heater shall be routed downward, which will prevent condensed water from slipping off the connector cable and entering the Heater.

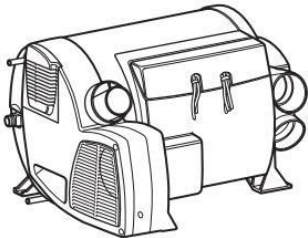

Figure 22

The connector cable and plug must not be stressed. Tie the connector cable (see figure 23) and fix it to the housing with a tie to eliminate tension. All cables must be firmly connected together and cannot be loosened or disconnected due to vibration. This may cause fire hazard!

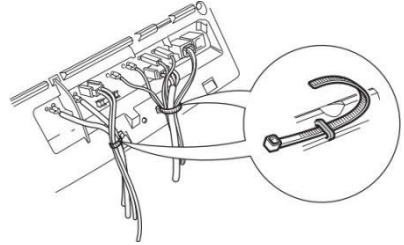

Figure 23

DC12V Power supply

The electrical wiring, switches and control equipment of the Heater must be located in a position that will not adversely affect its operation under normal operating conditions.

The Heater has reverse polarity protection. If the controller is not connected with the correct polarity, the LED indicator will not work. To ensure the best power supply, the Heater must be connected to the on-board power supply (or battery) protected by fuse (10A) with $2 \times 2.5\text{mm}^2$ cable ($2 \times 4\text{mm}^2$ if the length exceeds 6m).

If necessary, the voltage drop of the power supply line must be considered.

Connect the negative line to the main ground.

If the Heater is directly connected to the battery, the positive and negative lines must be protected.

Do not connect other power consuming devices.

Electric connection of oil pump

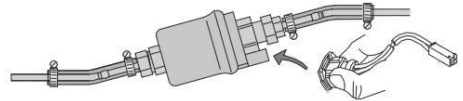

Figure

24

Please ensure that the plug is firmly connected.

Wiring diagram

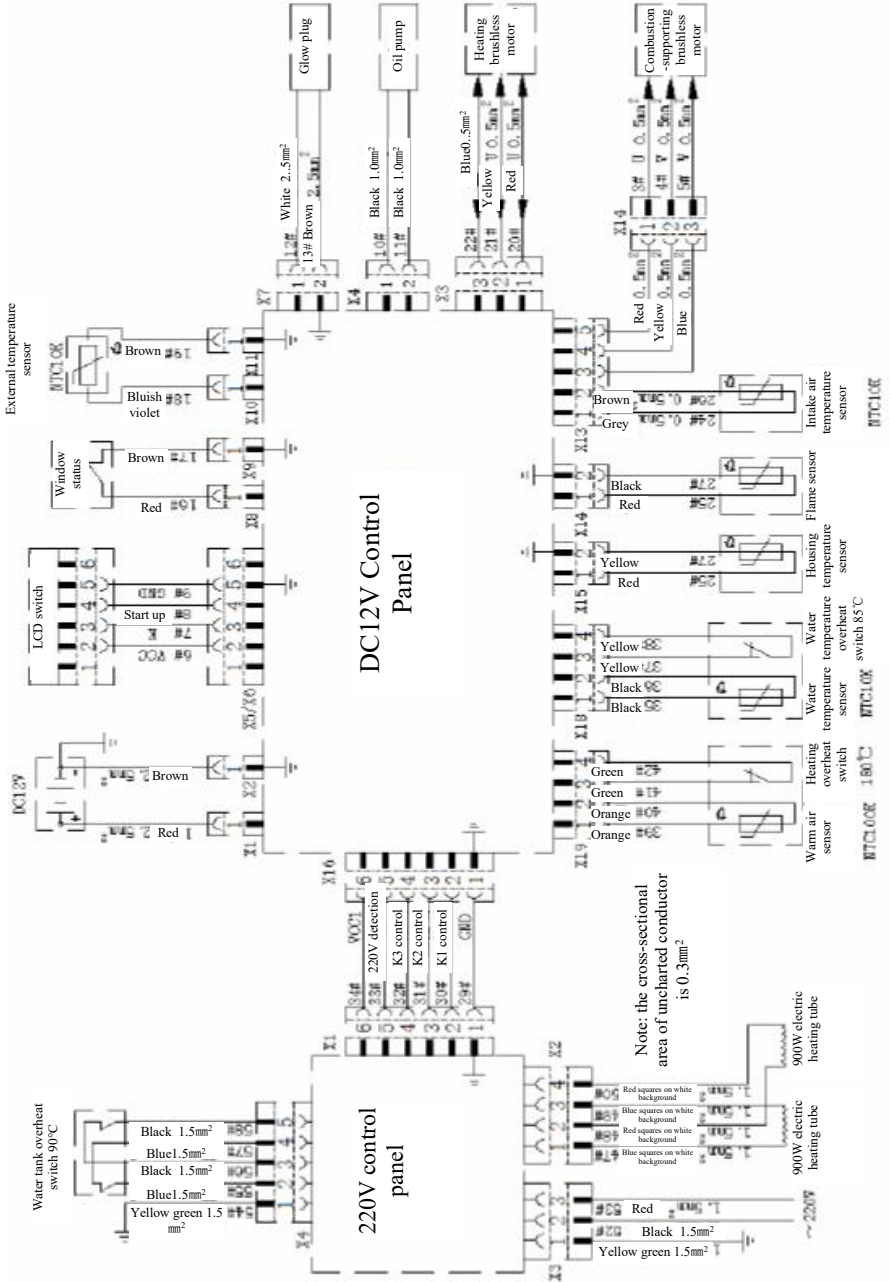

Figure 25

6. Operational precautions

The Heater shall not be operated during refueling or in confined spaces (closed parking lots, repair workshops or ferry cabins).

Regularly check whether the intake and exhaust pipes are in good condition and whether the fixing is reliable, especially after a trip. Also check the fixing of the intake and exhaust pipes and the exhaust cowl.

If black smoke is found, please ask the Company's authorized professionals to carry out maintenance.

Ensure that the exhaust pipe and the air inlet pipe at the smoke exhaust cowl are unobstructed and free from blockage such as snow mud, ice, leaves, etc.

Warm air outlet and circulating air inlet shall be unobstructed to avoid overheating of the Heater. In case of overheating, the overheat switch will immediately cut off the diesel supply.

The Heater shall be equipped with safety cut-off device to meet the heating needs during driving.

★ If there is no safety cut-off device, the Heater must be turned off before driving.

12V fuse

Only identical fuse T20A is allowed to be used for replacement.

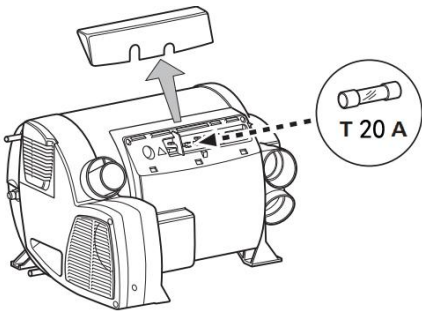

Figure 27

~220V fuse

★ Fuses and wire harnesses must be replaced by professionals authorized by the Company.

★ All power must be disconnected before opening the control enclosure.

Fuse specification: T20A slow blow

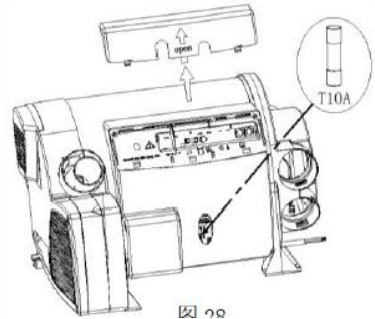

Figure 28

~220V overheat protection

The electrical heating function has a mechanical overheat protection switch. If the 12V power supply is interrupted during or after the heating process, the waste heat of the Heater will trigger the overheat protection switch.

After the temperature of the water tank decreases, disconnect the **~ 220 V power supply**, remove the controller cover plate, and manually press the reset button to reset the overheat protection switch.

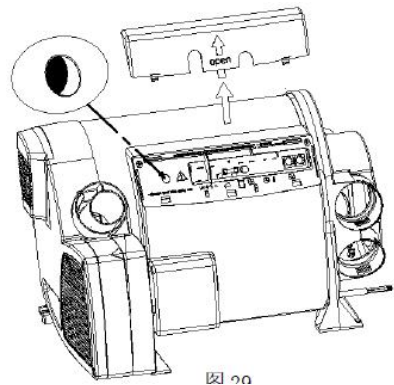

Figure 29

7. Operation instructions

Please read the operating instructions carefully before operating.

Start of the Heater

Operate with dedicated LCD switches.

The main machine heating by diesel, electrical, mixed mode, heated water tank or unheated water is set as required.

Check the power supply capacity of electrical in motor home camp and select electrical mode

900W(3.9A) or 1800W(7.8A) mode accordingly.

-check whether the smoke exhaust cowl is unobstructed

-Fill the water tank with water when needed.

Water filling

Check whether the safety valve/drain valve is closed.

---Turn on the power supply of the water pump (main brake or pump switch)

---Open the hot water faucet in the kitchen or bathroom and keep the valve open until the air in the container is exhausted and the water is continuously discharged.

---Without water heater heating, if only the cold water system is running, the water heater will be filled with water. To avoid frost damage, the water heater must be drained through a safety/drain valve, even if it is not in operation.

---In case of frost, frozen residual water can prevent filling. The water heater only needs to be turned on for a while to defrost.

(no more than 2 minutes). The frozen part can be thawed after heating the inside of the water heater.

---If the heater is connected to a central water supply system (rural or urban), a pressure reducer must be used to prevent the pressure from exceeding 2.8bar(0.28MPa).

-turn on the circulating water pump

-turn on the hot water faucet in the kitchen and bathroom until the air is exhausted to fill up the water tank and the water outlet will not be interrupted.

Turn off the Heater

-Operate with dedicated LCD switches.

-After the heater is turned off, the combustion-supporting fan and the heating fan will continue to work for several minutes according to the temperature of the furnace body.

In case of freezing hazard, the water tank must be emptied.

-Turn off the circulating water pump

-Turn on the hot water taps in the kitchen and bathroom.

Drainage of the Heater

---If the motor home is not used during frost. The Heater must drain the water.

---Turn off the power supply of the pump unit (main power supply or pump switch).

---Turn on the hot tap in the kitchen and bathroom.

---To check the outflow of water, place a suitable container under the drain tank of the safety/drain valve (installation by users; used to manually drain the water tank. The anti-freezing valve cannot ensure that the water tank is completely emptied.).

-Turn on the safety/drain valve.

---The water in the Heater will be directly discharged to the outside through the safety/drain valve. Check whether all water in the heater has been drained into the container through the safety/drain valve. No claim for damages caused by frost is allowed during the warranty period.

★ Use 10L bucket to collect water for inspection to ensure that the water tank is empty.

Maintenance/repair/cleaning

-The device can only be repaired and cleaned by professionals.

-Maintenance, repair and cleaning cannot be done by children.

-Flush all hot/cold water hoses thoroughly before using the new equipment or after the equipment has not been used for a period of time.

8. Fault

8.1 Handling of general faults

8.1.1 During the use of the Heater, the Heater may fail to start normally or shut down automatically after starting and be in a fault locking state. At this time, the Heater can be turned off for more than 5S and turned on again.

8.1.2 The Heater may cause circuit faults due to the following reasons: corrosion of connectors, poor contact, wrong insertion, corrosion of wires or fuses, corrosion of pile heads of storage batteries, etc. During use, pay attention to inspection, maintenance and prevention of these phenomena.

8.1.3 Users can handle and eliminate the following situations by themselves:

- After startup, the Heater does not start and the LCD switch screen is not bright, which is due to open fuse or wrong wiring; in addition, check whether the plug on the LCD switch lead is properly connected with the main machine.

8.2 Fault locking

8.2.1 The fault generated by the Heater shall be displayed by the fault code on the LCD switch.

8.2.2 The faults can be eliminated according to the methods listed in Table 2.

Troubleshooting Method for Fault Locking State		
Fault code	Fault name	Troubleshooting methods
10	Extremely high voltage	a check vehicle power supply system
11	Extremely low voltage	a check vehicle power supply system
21	Open circuit of warm air outlet temperature sensor	a check whether the sensor is in good condition.
22	Short circuit of warm air outlet temperature sensor	a check whether the sensor is in good condition.
23	Open circuit of water temperature sensor	a check whether the sensor is in good condition.
24	Short circuit of water temperature sensor	a check whether the sensor is in good condition.
25	Open circuit of external temperature sensor	a check whether the sensor is in good condition.
26	Short circuit of external temperature sensor	a check whether the sensor is in good condition.
27	Open circuit of combustion-supporting temperature sensor	a check whether the sensor is in good condition.
28	Short circuit of combustion temperature sensor	a check whether the sensor is in good condition.
31	Ignition failure	a check the diesel supply system b check whether the combustion-supporting inlet and outlet are blocked c check glow plug and flame sensor

Table 2

Troubleshooting Method for Fault Locking State		
Fault code	Fault name	Troubleshooting methods
32	Combustion failure	a check the diesel supply system b check whether the combustion-supporting inlet and outlet are blocked c check the flame sensor.
33	Flame sensor failure	a check flame sensor leads b check flame sensor
41	Warm air outlet temperature is too high	a check whether the air inlet and outlet are blocked
42	Warm air overheat switch protection	a check whether the air outlet is blocked b check the heater overheat switch
43	Water temperature is too high	a check whether the water tank is short of water. b check whether the sensor is in good condition. c check whether the air outlet is blocked
44	Water temperature overheat switch protection	a check whether the air outlet is blocked b check the water temperature overheat switch
45	Continuous overheat fault	a check whether the air outlet is blocked b check the water temperature sensor c check heater sensor
51	Communication failure	a check the connection cable
61	Open circuit of oil pump	a check whether the oil pump lead is damaged b check whether the oil pump lead connection is reliable. c replace oil pump d replace motherboard
62	Oil pump short circuit	a check whether the oil pump lead is damaged b check whether the oil pump lead connection is reliable. c check oil pump d replace motherboard
63	Open circuit of glow plug	a check power supply voltage b check the normal temperature resistance of glow plug (0.2Ω/12V) c clean up carbon deposits in glow plug d replace motherboard

Table 2 continued

Troubleshooting Method for Fault Locking State		
Fault code	Fault name	Troubleshooting methods
65	Glow plug has no drive	a replace motherboard
81	Open circuit of combustion-supporting fan	a check combustion-supporting fan
82	Combustion-supporting fan failed to start	a check motor lead connection b check combustion-supporting fan
83	The speed of combustion-supporting fan is too low.	a check combustion-supporting fan
84	Open circuit of heater fan	a check the heater blower.
85	The warm air blower failed to start.	a check motor lead connection b check the heater blower
86	The speed of warm air blower is too low.	a check the heater blower.
110	Window opening alarm	a check window switch connection cable
120	Low voltage alarm	a recommend charging
220	220V no connection	a check AC 220V power supply system
169	Power reset	a. Whether the power cord is directly connected to the battery, b. Insurance on the host c. Whether the source is sufficient, the power supply is pulled down a lot when the heater starts

Table 2 Continued

9. Precautions

● First installation

–If the Heater is installed for the first time, it is necessary to fill up the diesel pipe with diesel to completely remove air from the oil supply system. And a separate oil pumping function is specially designed. Please refer to the LCD switch manual for details.

–Flush the water tank with clean water before installing and using the Heater for the first time. When the Heater is not in use, please empty the water tank to avoid freezing the water tank. The Company does not bear the responsibility of water tank damage caused by freezing.

–Turn on the circulating water pump

–Turn on the hot water faucet in the kitchen and bathroom until the air is exhausted to fill up water tank and the water outlet will not be interrupted.

–The Heater shall be tested before use. During the trial run, all connections shall be carefully checked for leakage and safety. If there is smoke emission, abnormal combustion noise or diesel smell, the Heater shall be turned off and the fuse shall be pulled out to prevent the Heater from running. It can only be used after being overhauled by professional personnel.

–Odor may be emitted for a short time when the Heater is first used. This is normal in the first few minutes of operation. It does not mean that the Heater is malfunctioning.

● Quarterly maintenance

–Before each heating season, professional personnel must carry out an inspection and carry out the following maintenance work:

Check the air inlet and outlet for contamination and foreign matter.

Clean the outside of the Heater.

Check the circuit connector for rust and looseness.

Check whether the intake and exhaust pipes are blocked or damaged.

Check the diesel line for leaks.

● Long-term shutdown

—When the Heater is **not in use for a long time, it shall be operated every 4 weeks for about 10 minutes each time to prevent mechanical components such as oil pump or combustion air fan from malfunctioning** (stuck).

–The air inlet and outlet of the Heater must be kept free

from blockage and dirt, so that the warm air duct can be unblocked to prevent overheating.

–When replacing low-temperature diesel, the Heater shall be operated for at least 15min before filling the diesel system with new oil.

● Service life of the Heater

–The service life of the heat exchanger of the Heater shall not exceed 10 years. After expiration, genuine parts must be used for replacement. The replacement shall be performed by the heater manufacturer or its authorized agent.

–The exhaust pipe of the Heater, which discharges combustion exhaust gas, must be replaced with genuine parts when it is used for 10 years.

● Other precautions

–**The water tank must be descaled regularly, at least twice a year.**

–During the transportation and storage of the Heater, its ambient temperature shall not exceed the range of -40°C to 85°C so as to prevent electronic components from being damaged.

–Only authorized customer service stations are allowed to install and repair heaters, and non-original parts are prohibited to avoid danger.

–For the Heater damaged due to installation and operation not in accordance with regulations, the manufacturer is not responsible for warranty.

–The Heater must be turned off before refueling.

–When performing electric welding on the vehicle, the positive power supply line of the Heater shall be removed from the battery and grounded to prevent damage to the controller.

10. Packing list

Packing list				
No.	Name	Specification	Quantity	Order code
1	Instructions	YJH-4/1C-E Host	1	22020203400
2	Main machine of the Heater	YJH-4/1C-E	1	4T300612C01
3	Cross head self-tapping nail	ST5*25	5	12050016100
4	12V power cord	4m	1	12031101600
5	External temperature sensor	NTC10K L=4m	1	31011102100
6	LCD switch	MNB-V-FY	1	31011104400
7	LCD switch lead	6m	1	12031101500
8	Controller cover	260×75×22	1	12021100900
9	Cross head self-tapping screw	ST5×16	4	12050007300
10	Outer wire clamping sleeve joint	G1/2-φ10	2	12011104300
11	Nylon cable ties	4×200	10	21990000000
12	Air inlet and outlet body	φ110×108	1	12011101900
13	Inlet and outlet cover	φ110×34	1	12021102000
14	Sealing washer	φ104.5×φ73×2.4	1	12041101800
15	Clamp	φ55	2	31011102700
16	German clamp	70-90	2	12050200700
17	Air inlet pipe fixing clip	φ80	1	12021102700
18	Cross head self-tapping screw	ST3.5×25	9	12050015600
19	Outlet pipe	φ55/φ50×950	1	12060007700
20	Inlet pipe	φ80/φ76×1000	1	12060007800
21	Air outlet	CFK-φ60-III Resilience adjustable	4	31011104700
22	Reducing valve	0.5MPa	1	12501101000
23	Drain valve	1~4°C	1	31011106600
24	German clamp	φ50-φ70	4	12010005100
25	Ducting buckle	φ60	4	12021102600
26	Oil pump assembly	YB-1-12V with buffer	1	33000007600
27	Oil pump fixing sleeve	φ32×29	1	12990007300
28	Fuel filter assembly	CX0708(4100) with aluminum seat and combination pad	1	12500005400
29	Oil pipe connector	φ3.5/φ9.5 L=40	3	12060003900
30	Oil pipe connector	φ4.1/φ10.5 L=40	4	12060003800
31	Oil pipe clamp	φ8~10 (9)	5	12010004300
32	Oil pipe clamp	φ9~11 (10)	9	12010004200
33	Oil pipe (from oil pump to main machine)	Nylon tube φ4×1 L=6800 transparent	1	12060004200
34	Oil pipeline (from oil pump to oil tank)	Nylon tube φ5×1.5 L=1200 blue	1	12060004600
35	Oil pump harness	L=6800	1	12031200300
36	Self-drilling self-tapping screw	ST5.5×30	3	12050003000
37	Oil suction pipe	XYG-IIφ5×600	1	31000000500
38	Reducing tee-junction	10-6-10	1	12020015700
39	Mini clamp	12-14	2	12010004600
40	Composite ducting	Φ60 L=4000	2	12060008800

Note: Items 12 to 40 are additionally packed in the accessory box. Those out of the packing list are optional

accessories which can be provided by the Company as required.